

Vital statistics

Technical details, floor plans
and capacity charts

The technical stuff



Venue overview

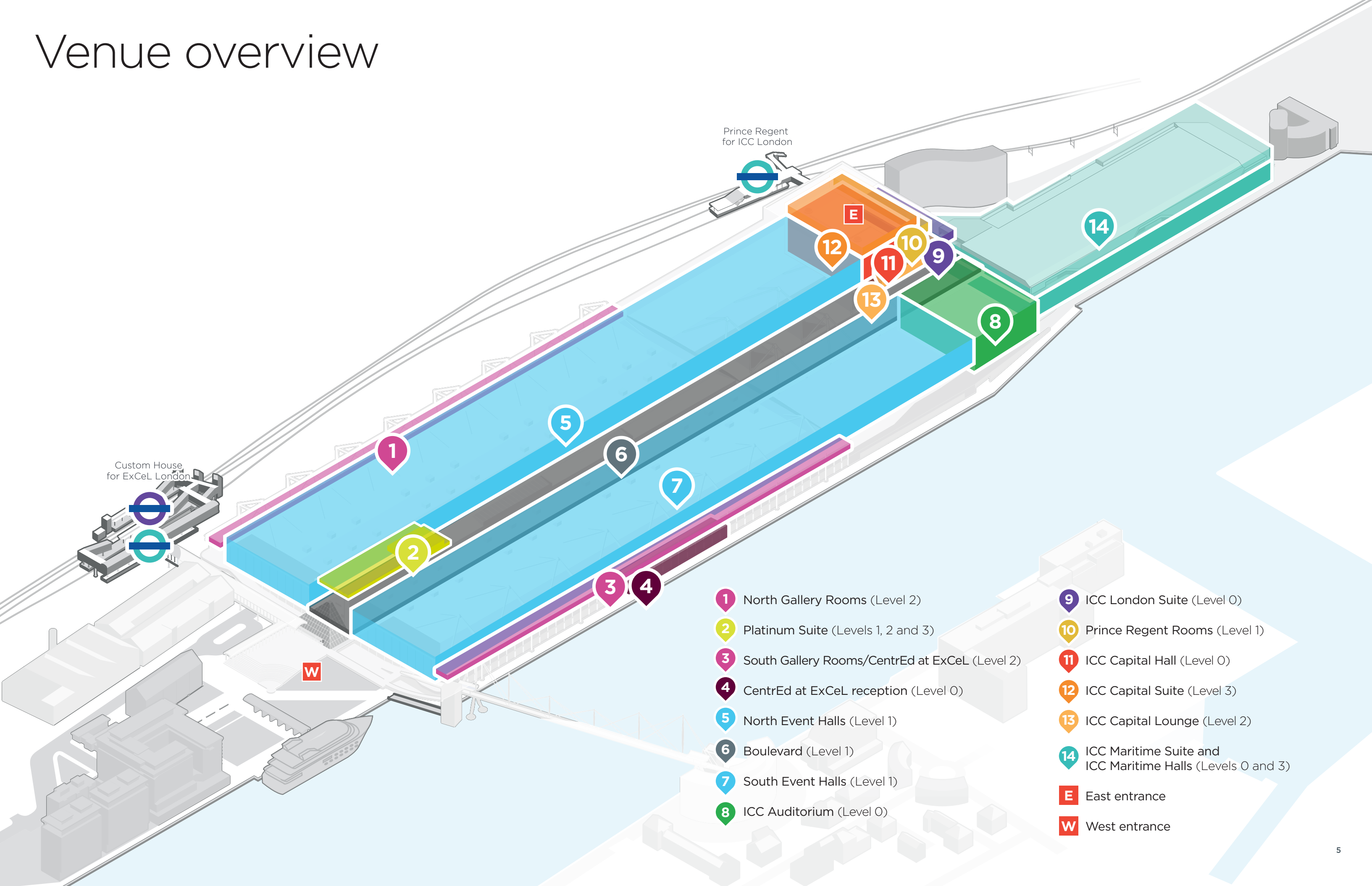

- 1 North Gallery Rooms (Level 2)
- 2 Platinum Suite (Levels 1, 2 and 3)
- 3 South Gallery Rooms/CentrEd at ExCeL (Level 2)
- 4 CentrEd at ExCeL reception (Level 0)
- 5 North Event Halls (Level 1)
- 6 Boulevard (Level 1)
- 7 South Event Halls (Level 1)
- 8 ICC Auditorium (Level 0)
- 9 ICC London Suite (Level 0)
- 10 Prince Regent Rooms (Level 1)
- 11 ICC Capital Hall (Level 0)
- 12 ICC Capital Suite (Level 3)
- 13 ICC Capital Lounge (Level 2)
- 14 ICC Maritime Suite and ICC Maritime Halls (Levels 0 and 3)
- E East entrance
- W West entrance

Event Halls

Level 1

Key features

- Total capacity: 68,750 guests
- 939,649 sq ft column free space (divided into North & South event halls)
- 21,520 sq ft hall modules (N2-N22 & S2-S22): 283.4 ft (l) x 77 ft (w) x 33 ft (h)
 - N1 & S1: 10,760 sq ft x 33 ft (h)
 - N23 & S23: 7,145 sq ft x 33 ft (h)
- ICC Maritime Hall modules
 - Hall 1: 17,991 sq ft x 28.8 ft (h)
 - Hall 2: 18,217 sq ft x 28.8 ft (h)
 - Hall 3: 21,993 sq ft x 28.8 ft (h)
 - Hall 4: 22,790 sq ft x 28.8 ft (h)
 - Hall 5: 22,101 sq ft x 28.8 ft (h)
 - Hall 6: 20,874 sq ft x 28.8 ft (h)
- Easy visitor access from 129,120 sq ft (1,968 ft long) central boulevard (Level 1)
- Partitioned floor space with moveable walls
- Private lorryway accessing event halls with 24.6 ft (w) x 16.4 ft (h) drive-in doorways
- Event Hall floor weight loading: 18 kN/10 sq ft
- Marshalling area for 300 vehicles
- Permanent cabling including IT, electric, water, waste, compressed air, gas - serviced by underfloor ducts every 16.4 ft North to South and 9.8 ft East to West
- Individually adjustable LED ceiling lights every 17.7 ft
- Ability to rig and truss from anywhere in the ceiling

Locator map

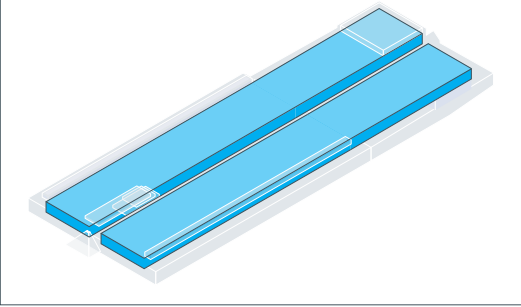

Key

- Organiser offices
- Toilets
- Lifts
- Stairs



Platinum Suite

Levels 1, 2 & 3

Platinum Suite - capacity chart

Platinum room (Level 3) configuration options

	Area	Dimensions	Height	Theatre	*Schoolroom	*Cabaret	*Banquet	Reception	Boardroom
Room 1 or 2 or 3 or 4	4,218 sq ft	46 ft x 92 ft	15 ft	360	200	192	240	360	n/a
Rooms 1+2 or 3+4	8,436 sq ft	92 ft x 92 ft	15 ft	680	400	384	480	720	n/a
Rooms 1-4	16,871 sq ft	92 ft x 184 ft	15 ft	1,125	840	800	800	1,125	n/a
Titanium room	422 sq ft	12 ft x 35 ft	15 ft	n/a	n/a	20	n/a	15	20
Zinc room	241 sq ft	12 ft x 19 ft	15 ft	n/a	n/a	10	n/a	n/a	10
Organiser office	126 sq ft	10 ft x 13 ft	15 ft	n/a	n/a	8	n/a	n/a	6

Platinum lounge and rooms 5, 6 and 7 (Level 2) configuration options

	Area	Dimensions	Height	Theatre	*Schoolroom	*Cabaret	*Banquet	Reception	Boardroom
Full use of lounge and rooms	6,994 sq ft		9.6 ft	260	n/a	n/a	n/a	600	n/a
Room 5	560 sq ft	18 ft x 31 ft	9.6 ft	70	24	32	40	70	20
Room 6	732 sq ft	24 ft x 31 ft	9.6 ft	90	30	32	50	90	20
Room 7	560 sq ft	18 ft x 31 ft	9.6 ft	70	24	32	40	70	20
Full use of rooms 5, 6 and 7 only	1,851 sq ft	60 ft x 31 ft	9.6 ft	260	100	104	130	260	40
Rooms 5, 6, 7 and breakout reception	3,120 sq ft	60 ft x 51 ft	9.6 ft	n/a	n/a	160	200	300	40
Rooms 5+6	1,291 sq ft	42 ft x 31 ft	9.6 ft	180	80	80	100	180	30
Rooms 6+7	1,291 sq ft	42 ft x 31 ft	9.6 ft	180	80	80	100	180	30

All capacities subject to floorplan approval.

*Schoolroom numbers are based on three per table (using 6 ft trestle tables); *Cabaret numbers based on a max of eight per table (using 5 ft round tables);

*Banquet numbers based on a max of ten per table (using 5 ft round tables).

Platinum rooms 1 to 4

Facilities

- Dimmable house lighting
- All rooms fully blacked out (except for fire lights and vision panels in doors)
- Heating and cooling
- 57Db noise resistant partition wall
- Feature wall lighting
- PA system

Door dimensions

- 4.9 ft (w) x 8.5 ft (h)

Freight lift dimensions & weight loading

- Lift size: 10.3 ft (w) x 19.3 ft (d) x 9.8 ft (h)
- Door size: 10.3 ft (w) x 9.8 ft (h)
- Weight loading: 11,330 lbs

Goods lift dimensions & weight loading

- Lift size: 5.6 ft (w) x 8.8 ft (d) x 7.7 ft (h)
- Door size: 4.2 ft (w) x 6.8 ft (h)
- Weight loading: 5,511 lbs

Maximum occupancy (entire suite)

- 1,125 people

Maximum loading

- Floor: 5.0 kN/10 sq ft
- Roof: 0.6 kN/10 sq ft
- Lighting bar loading is 330 lbs per singular bar with a load of 55 lbs per linear metre
- Six additional rigging points per quarter which are 550 lbs per point load

Platinum Suite Lobby

- 25.2 ft x 99.5 ft
- Total: 2,507 sq ft

Additional power available on request

- 63 AMP 3 phase
- 125 AMP 3 phase
- 32 AMP 3 phase

Platinum rooms 5 to 7

Facilities

- Dimmable house lighting
- Heating and cooling
- 57Db noise resistant partition wall
- PA system

Door dimensions

- 4.9 ft (w) x 8.5 ft (h)

Maximum loading

- Floor: 5.0 kN/10 sq ft
- Roof: 0.6 kN/10 sq ft

Equipment available on request

- Projector screen
- Ceiling projection mounting point

Platinum boardroom

Dimensions

- 22.5 ft (w) x 14.4 ft (l) x 7.5 ft (h)
- Total - 109.5 sq ft
- Boardroom layout for 16 people

Facilities

- Dimmable house lighting
- Heating and cooling
- Sound proof walls
- Storage cupboards

Door dimensions

- 2.4 ft (w) x 7.2 ft (h)

Maximum loading

- Floor: 5.0 kN/10 sq ft

Equipment available on request

- LED screen with remote connectivity
- Logitech Meetup VC system
- Kramer Go2 Wireless Connection

Locator map

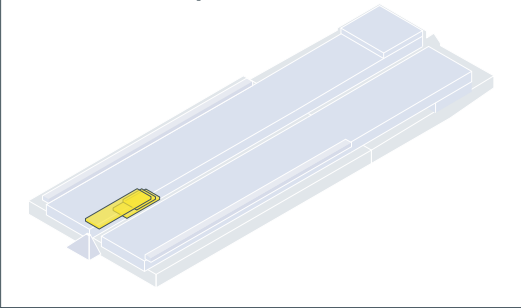

Platinum Suite - Level 3

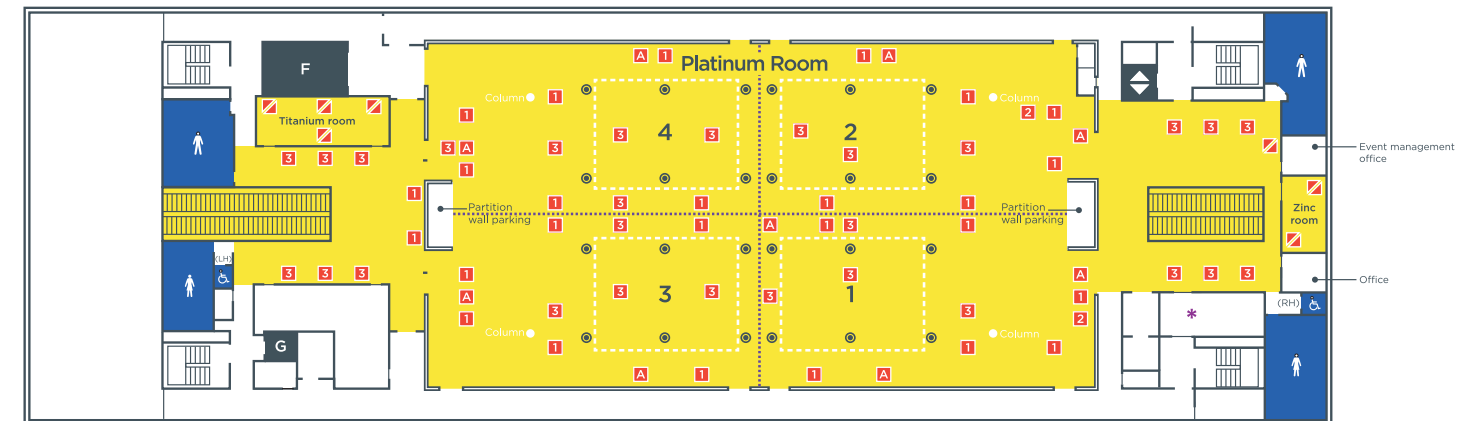

Key

- 1** Floor box type 1
2x 13 AMP sockets
4x jack plugs
- 2** Floor box type 2
2x 13 AMP sockets
1x 15 PIN female PC socket
1x video jack
2x 15 pair audio sockets (L & R)
1x 13 AMP projector plug
- 3** Floor box type 3
2x 13 AMP sockets
4x jack plugs + 2 spares
- A** 3 phase power supply available on request
- ▬** Pair fused and switched
13 AMP sockets
- IM plasma screen
- ♂** Toilets
Male
- ♀** Female
- ♿** Accessible (RH/LH - Right/Left hand)
- ⬆** Lifts
Public
- G** Goods
- F** Freight
- ⋯** Partition wall
- ⊙** Rigging points (550lbs loads)
- Light bar/hanging point
- Demountable cloakroom counters

Platinum Suite lounge and meeting rooms - Level 2

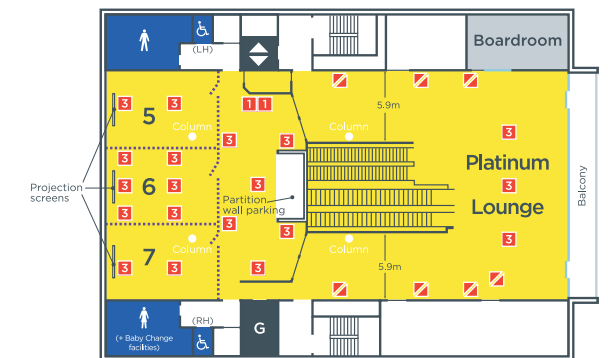

Platinum Suite lobby - Level 1 (Boulevard)

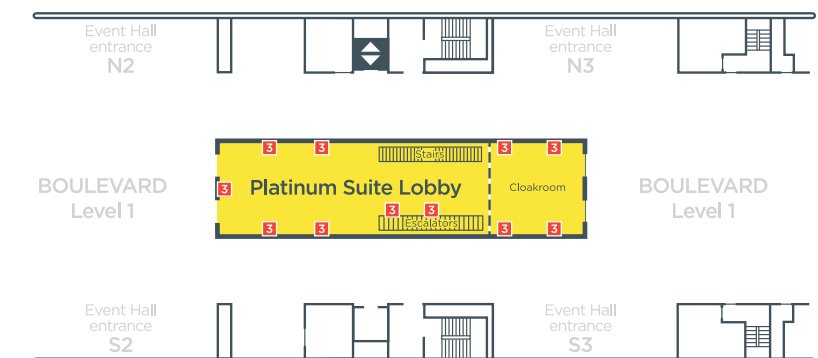

Gallery Rooms

Level 2

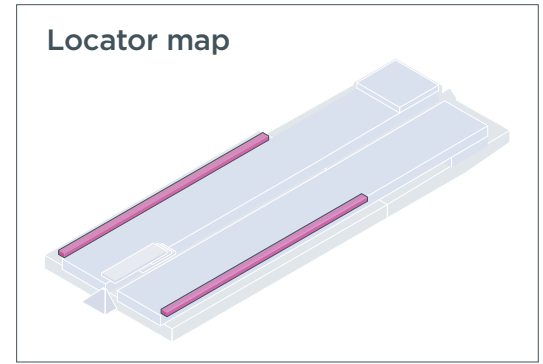

North Gallery Rooms



Please note: North Gallery Rooms 7, 11 and 18 are slightly indented due to the public lift

North Gallery Rooms detail plan - Rooms 4 to 7

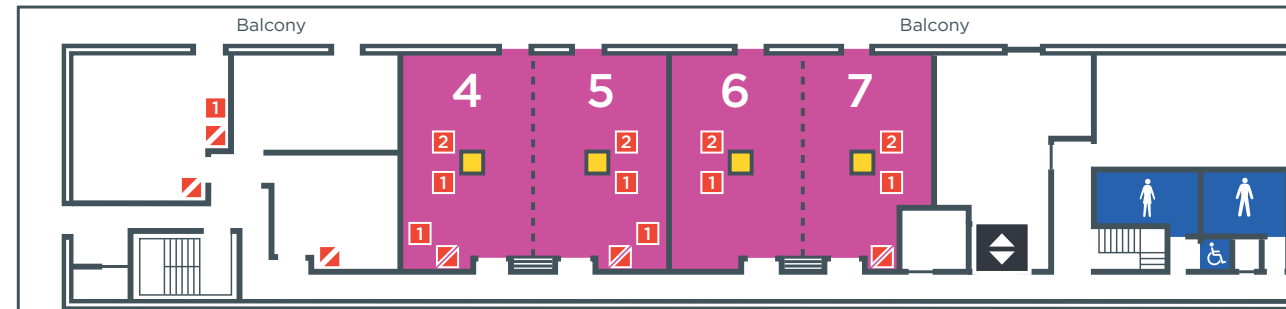

Single room: 18, 19, 20
 Double room: 4+5, 6+7, 8+9, 10+11, 12+13, 14+15, 16+17

South Gallery Rooms detail plan - Rooms 1 to 6

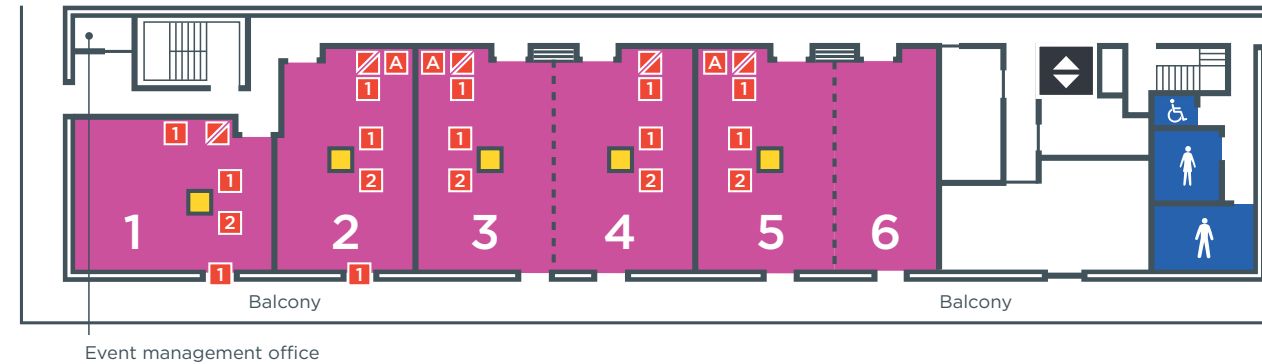

South Gallery Rooms



Large single room: 3, 4, 5, 7, 8, 9, 11, 12, 13, 15, 16, 17, 18, 20, 21, 23, 24, 25, 27, 28, 29
 Small single room: 6, 10, 14, 26
 Large double room: 3+4, 7+8, 8+9, 11+12, 15+16, 17+18, 20+21, 23+24, 27+28
 Small double room: 5+6, 9+10, 13+14, 19, 22, 25+26

North Gallery Rooms - capacity chart

	Area	Dimensions	Height	Theatre	*Schoolroom	*Cabaret	*Banquet	Reception	Boardroom
North Gallery Room 4, 5, 6, 13, 15 or 17	979 sq ft	39 ft x 25 ft	10.2 ft	90	42	48	60	90	34
North Gallery Room 7, 11 or 18	904 sq ft	29 ft x 25 ft	10.2 ft	70	42	40	50	70	34
North Gallery Room 8, 9, 10, 12, 14, 16 or 20	968 sq ft	39 ft x 25 ft	10.2 ft	90	42	48	60	90	34
North Gallery Room 19	2,949 sq ft	76 ft x 41 ft	10.2 ft	248	80	120	160	248	66

South Gallery Rooms - capacity chart

	Area	Dimensions	Height	Theatre	*Schoolroom	*Cabaret	*Banquet	Reception	Boardroom	U shape
Large Single Room	1,044 sq ft	42 ft x 25 ft	10.2 ft	90	40	48	60	90	34	23
Small Single Room	764 sq ft	42 ft x 18 ft	10.2 ft	70	28	24	30	60	34	23
Large Double Room	1,985 sq ft	42 ft x 50 ft	10.2 ft	200	98	96	120	200	50	47
Small Double Room	1,720 sq ft	42 ft x 43 ft	10.2 ft	180	80	72	90	180	44	41
South Gallery Room 1	1,033 sq ft	28 ft x 36 ft	10.2 ft	90	40	48	60	90	34	23
South Gallery Room 2	1,022 sq ft	25 ft x 42 ft	10.2 ft	80	40	40	50	80	34	23
South Gallery Room 29	1,033 sq ft	28 ft x 36 ft	10.2 ft	90	40	48	60	90	34	23
South Gallery Rooms 8-10, 18+19 or 21+22	2,975 sq ft	42 ft x 74 ft	10.2 ft	304	118	144	180	304	60	65
South Gallery Rooms 7-10, 17-19 or 20-22	3,704 sq ft	42 ft x 93 ft	10.2 ft	400	156	184	230	400	70	83

All capacities subject to floorplan approval.
 *Schoolroom numbers are based on three per table (using 6 ft trestle tables); *Cabaret numbers based on a max of eight per table (using 5 ft round tables); *Banquet numbers based on a max of ten per table (using 5ft round tables).

Gallery Rooms (Level 2)

Facilities

- Dimmable house lighting
- All suites are acoustically sealed
- All rooms have sun blinds
- Audio visual equipment available on request
- Heating and cooling
- Wardrobes available in rooms 11-22
- Natural daylight

Door dimensions

- 4.6 ft (w) x 6.6 ft (h)

Maximum loading

- Breakout areas: 5.0kn/10 sq ft

Passenger lift dimensions & weight loading

- Lift size: 3.6 ft (w) x 2.9 ft (d) x 6.9 ft (h)
- Door size: 3.6 ft (w) x 6.8 ft (h)
- Weight loading: 2,976 lbs

Key

- 1** Floor box type 1
2x 13 AMP sockets
4x jack plugs
- 2** Floor box type 2
2x 13 AMP sockets
1x 15 PIN female PC socket
1x video jack
2x 15 pair audio sockets (L & R)
1x 13 AMP projector plug
- A** 3 phase power supply available on request. Location available on technical plans
- 1** Ceiling projector mount point available on request
- Projection screens**
Location available on technical plans
- ...** Partition wall
- Toilets**
Male
Female
Accessible (RH/LH - Right/Left hand)
- Public lifts**
- Stairs**

Meeting & training rooms

Levels 0 & 2

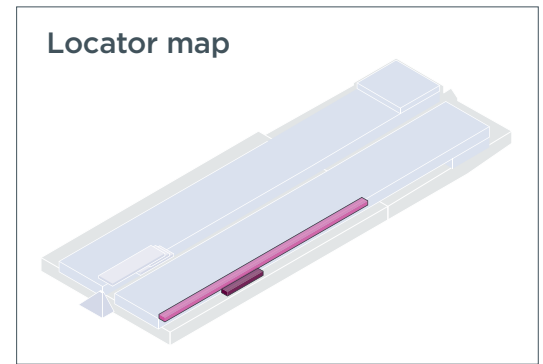

CentrEd at ExCeL - Level 2

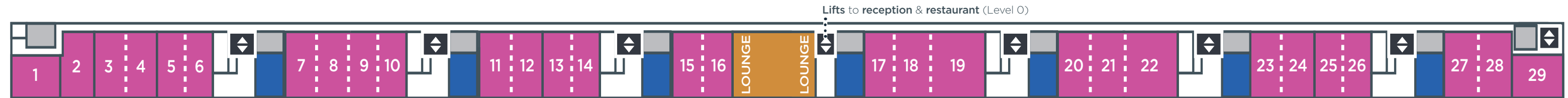

Large single room: 3, 4, 5, 7, 8, 9, 11, 12, 13, 15, 16, 17, 18, 20, 21, 23, 24, 25, 27, 28, 29
 Small single room: 6, 10, 14, 26
 Large double room: 3+4, 7+8, 8+9, 11+12, 15+16, 17+18, 20+21, 23+24, 27+28
 Small double room: 5+6, 9+10, 13+14, 19, 22, 25+26

Lifts to reception & restaurant (Level 0)

CentrEd at ExCeL - capacity chart

	Area	Dimensions	Height	Theatre	*Schoolroom	*Cabaret	*Banquet	Reception	Boardroom	U shape	*Exam
Large Single Room	1,044 sq ft	42 ft x 25 ft	10.2 ft	90	40	48	60	90	34	23	28
Small Single Room	764 sq ft	42 ft x 18 ft	10.2 ft	70	28	32	40	60	34	23	20
Large Double Room	1,985 sq ft	42 ft x 50 ft	10.2 ft	200	98	96	120	200	50	47	56
Small Double Room	1,720 sq ft	42 ft x 43 ft	10.2 ft	180	80	80	100	180	44	41	42
South Gallery Room 1	1,033 sq ft	28 ft x 36 ft	10.2 ft	90	40	48	60	90	34	23	n/a
South Gallery Room 2	1,022 sq ft	25 ft x 42 ft	10.2 ft	80	40	40	50	80	34	23	n/a
South Gallery Room 29	1,033 sq ft	28 ft x 36 ft	10.2 ft	90	40	48	60	90	34	23	n/a
South Gallery Rooms 8-10, 18+19 or 21+22	2,975 sq ft	42 ft x 74 ft	10.2 ft	304	118	144	180	304	60	65	n/a
South Gallery Rooms 7-10, 17-19 or 20-22	3,705 sq ft	42 ft x 93 ft	10.2 ft	400	145	184	230	400	70	83	119

All capacities subject to floorplan approval.
 *Schoolroom numbers are based on three per table (using 6 ft trestle tables); *Cabaret numbers based on a max of eight per table (using 5 ft round tables);
 *Banquet numbers based on a max of ten per table (using 5 ft round tables); *Exam numbers based on single exam desk.

CentrEd at ExCeL - Level 0

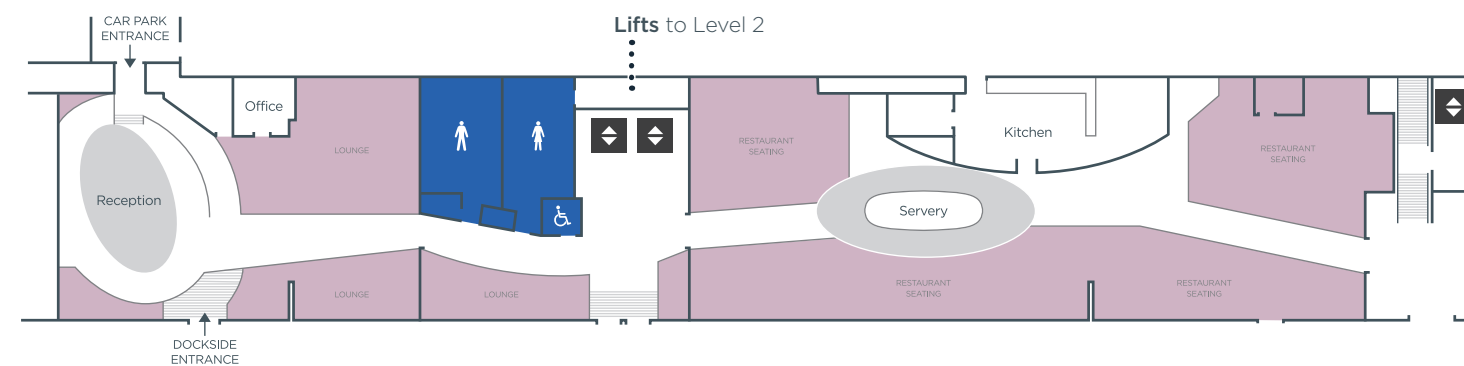

Facilities

- Dimmable house lighting
- All suites are acoustically sealed
- All rooms have sun blinds
- Ceiling projection mounting point
- Heating and cooling
- Wardrobes available in rooms 11-22
- Natural daylight

Reception

- Direct access to car park
- Internet stations
- Lounge area with self-service coffee machines

Restaurant

- Seated restaurant for 200 people

Level 2

- Lounge: 2,163 sq ft
- Lounge capacity: 90 people

Level 0

- Lounge: 4,456 sq ft
- Reception / Lounge capacity: up to 200 people
- Restaurant: 4,886 sq ft

Door dimensions

- 4.6 ft (w) x 6.6 ft (h)

Maximum occupancy

- Single rooms: 90 people
- Double rooms: 200 people

Maximum loading

- Breakout areas: 5.0 kN/10 sq ft



Passenger lift dimensions & weight loading

- Lift size: 3.6 ft (w) x 2.9 ft (d) x 6.9 ft (h)
- Door size: 3.6 ft (w) x 6.8 ft (h)
- Weight loading: 2,976 lbs

Key

 Partition wall

Toilets

-  Male
-  Female
-  Accessible

 Public lifts

 Stairs to Event Halls only

ICC London

Event spaces

Key

- 1 ICC Auditorium (Level 0)
- 2 ICC Capital Hall (Level 0)
- 3 ICC Capital Suite (Level 3)
- 4 ICC Capital Lounge (Level 2)
- 5 ICC London Suite (Level 0)
- 6 Prince Regent Rooms (Level 1)
- 7 Event Halls (Level 1)
- 8 Boulevard (Level 1)
- 9 Boulevard (Level 0)
- 10 ICC Maritime Suite and ICC Maritime Halls (Levels 0 and 3)
- 11 Prince Regent DLR walkway (Level 1)

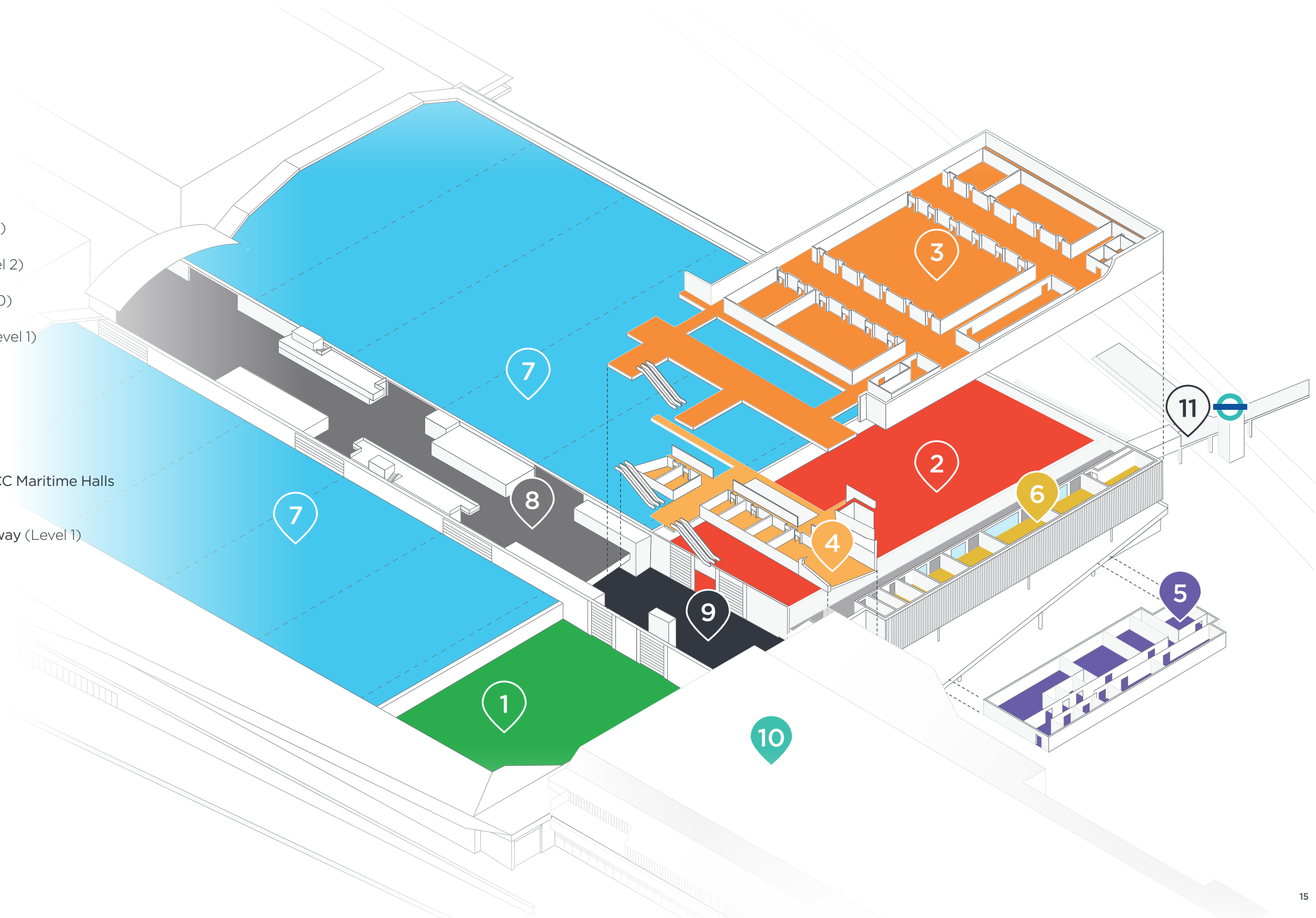

ICC Auditorium

Level 0

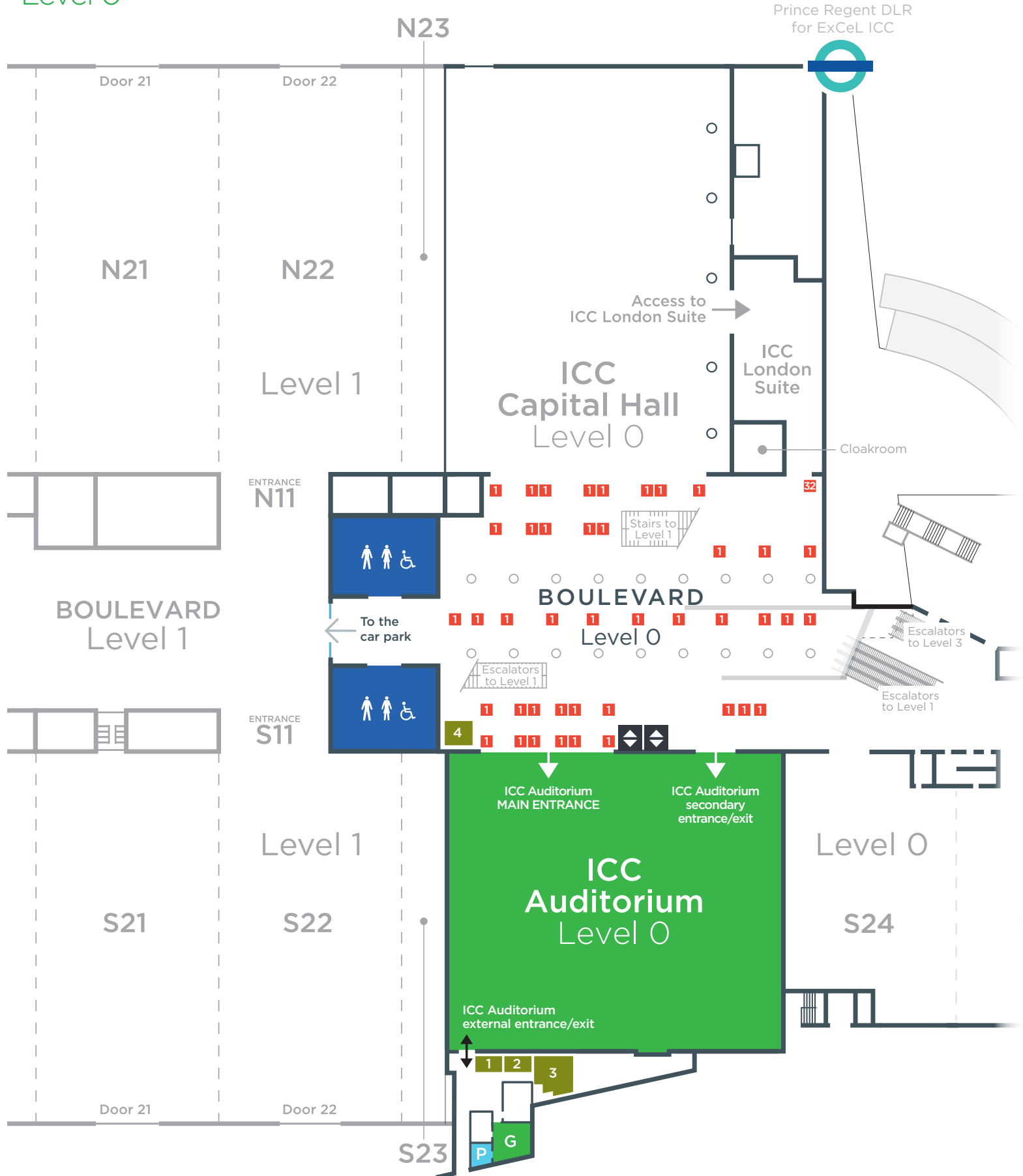

Floor plan examples

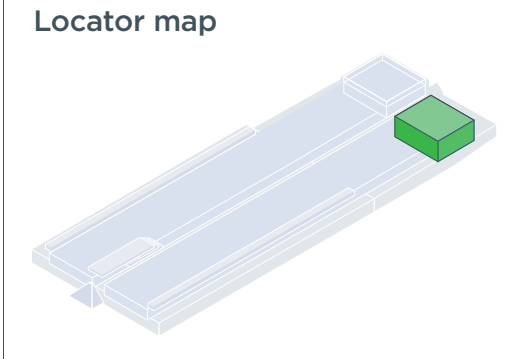

ICC Auditorium (Level 0)

- Seating for up to 4,200 delegates
- 49,528 sq ft space
- 238 ft (l) x 208 ft (w) x 49 ft (h)
- Acoustic panelling
- 7.2m wide drive-in doorways
- Floor weight loading: 18 kN/10 sq ft
- Permanent cabling including IT, electric, water, waste, compressed air, gas
 - Serviced by underfloor ducts every 16.4 ft North to South and 9.8 ft East to West
- Auditorium backstage rooms:
 - Green room: 28.5 ft x 28 ft, 662 sq ft total. Including furniture, phone, plasma screen, service pantry, toilets and shower
 - Organiser office 1: 7.3 ft x 21 ft, 147 sq ft total
 - Organiser office 2: 7.3 ft x 21 ft, 147 sq ft total
 - Organiser office 3: 26 ft x 26 ft, 686 sq ft total
 - Organiser office 4: 13 ft x 15.5 ft, 202 sq ft total
- AV and stage included
- Heating and cooling
- Easy access to and from ICC Capital Hall
- Boulevard: 18,346 sq ft

Key

- 1** Floor box type 1
2x 13 AMP sockets
4x jack plugs
- 32** 32 AMP single phase supply
- 4** Organiser offices
- P** Pantry
- G** Green room
- Columns
- Toilets**
 - ♂** Male
 - ♀** Female
 - ♿** Accessible
- ⬆️⬆️** Public lifts
- ▤** Tiered seating
- Flat floor seating
- }** Drape

ICC Capital Hall

Level 0

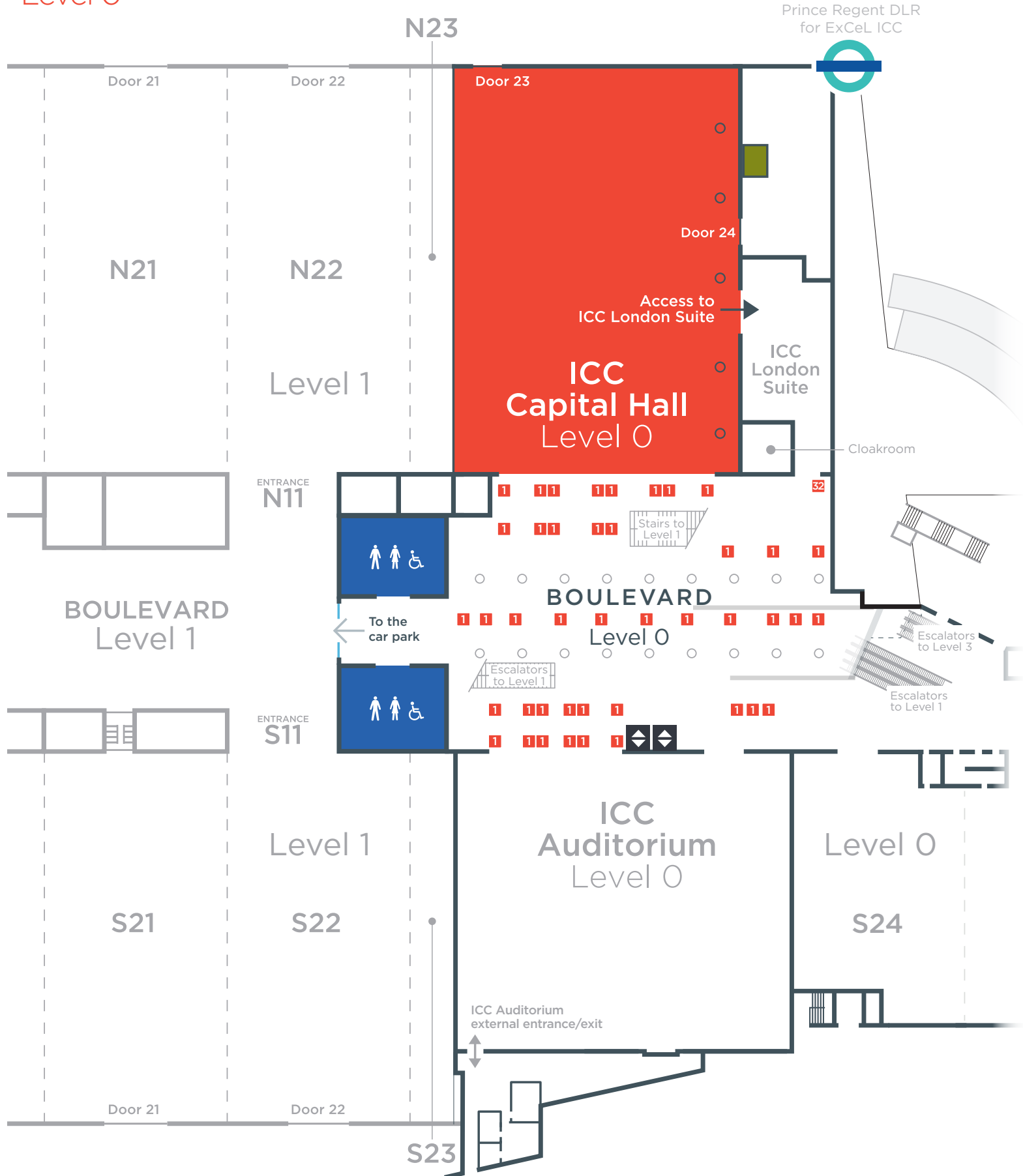

Floor plan examples

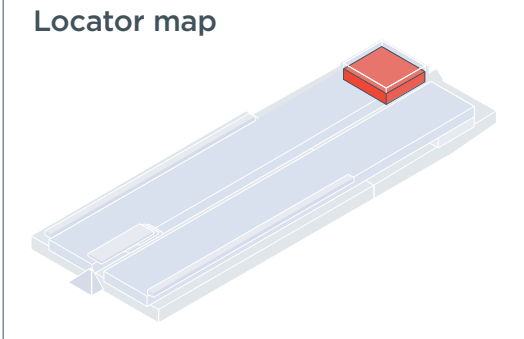
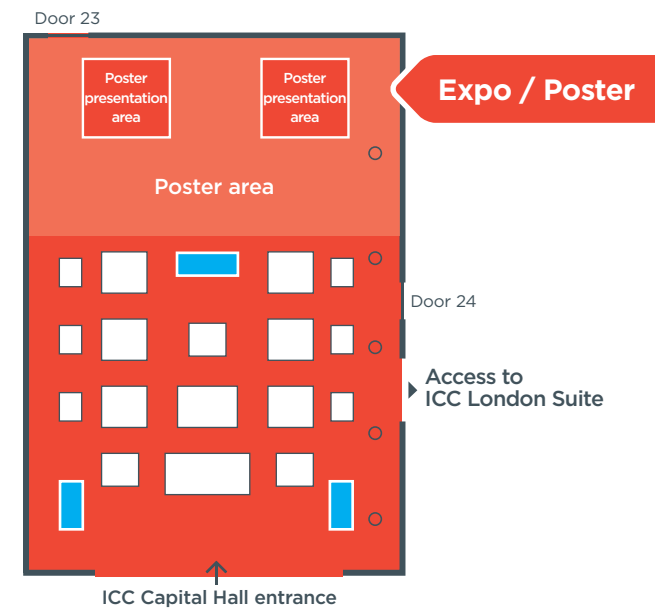
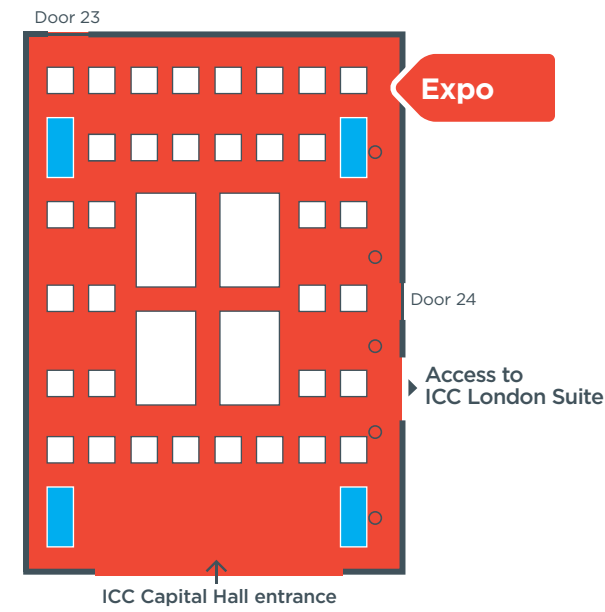
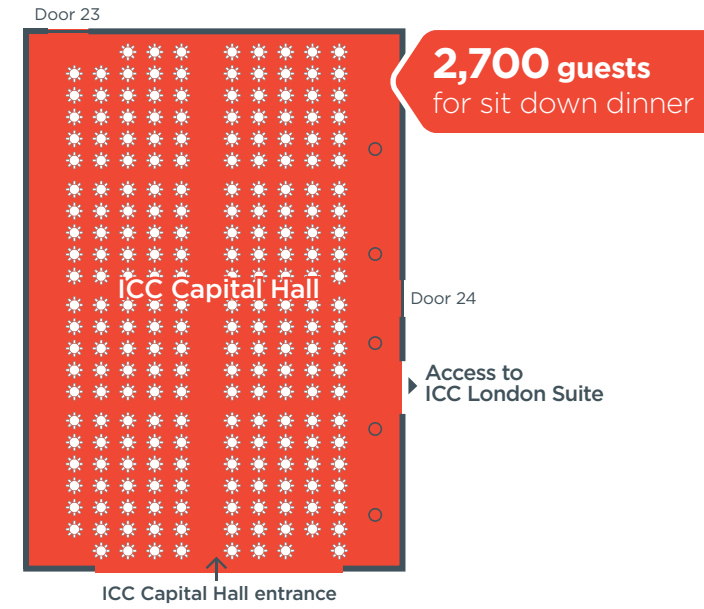

ICC Capital Hall (Level 0)

- Banquet for up to 2,700 guests
- Reception for up to 5,000 guests
- 48,527 sq ft space
- 283 ft (l) x 172 ft (w) x 32 ft (h)
- Lorry Doors (Door 23 and Door 24)
 - Door 24: 26 ft (w) x 17 ft (h)
 - Door 23: 24 ft (w) x 9 ft (h)
- Floor weight loading: 18 kN/10 sq ft
- Permanent cabling including IT, electric, water, waste, compressed air, gas
 - Serviced by underfloor ducts every 16.4 ft North to South and 9.8 ft East to West
- Production Kitchen (19,282 sq ft)
- Easy Access to and from the ICC Auditorium and direct access into ICC London Suite
- Organiser office
- Heating and cooling
- Boulevard: 18,346 sq ft

Key

- 1** Floor box type 1
2x 13 AMP sockets
4x jack plugs
- 32** 32 AMP single phase supply
- Organiser office
- Columns
- Toilets**
 - ♂** Male
 - ♀** Female
 - ♿** Accessible
- ⬆** Public lifts
- ☼** Tables & chairs (using 5 ft round tables)
- Exhibition stands
- Catering

ICC Capital Suite

Level 3

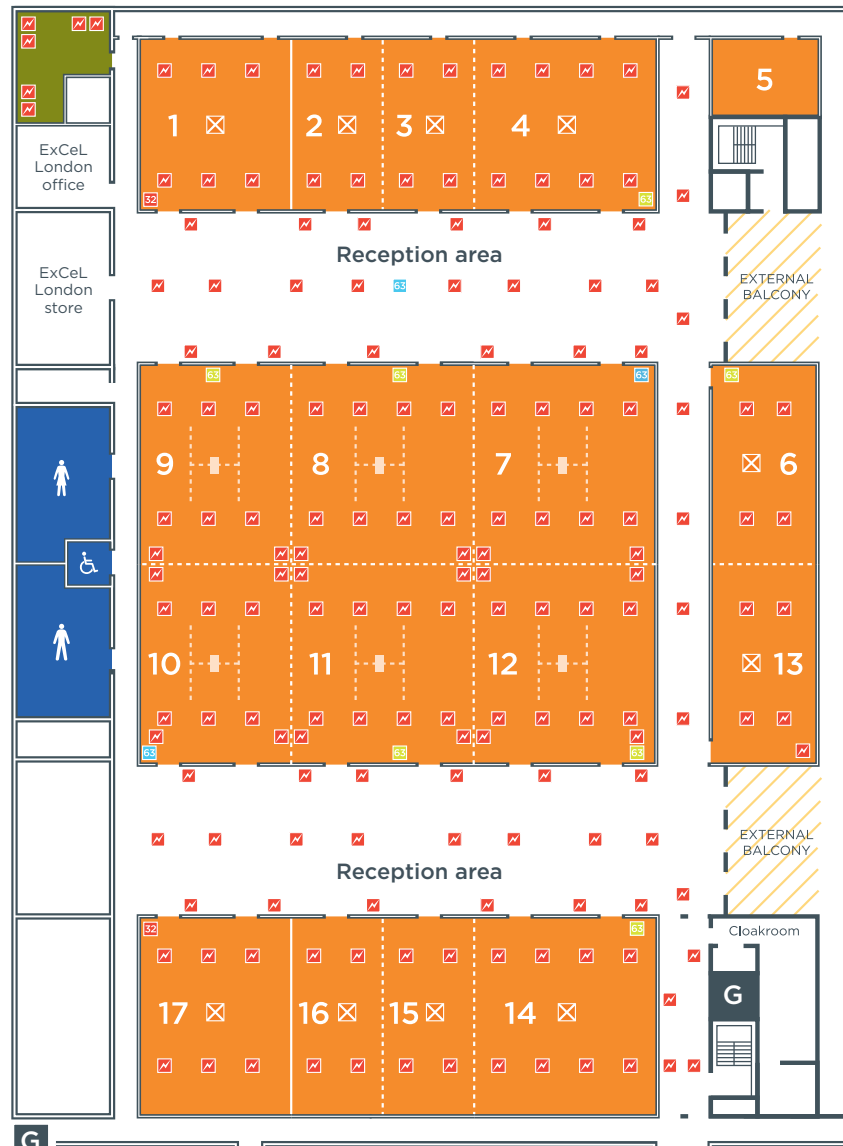
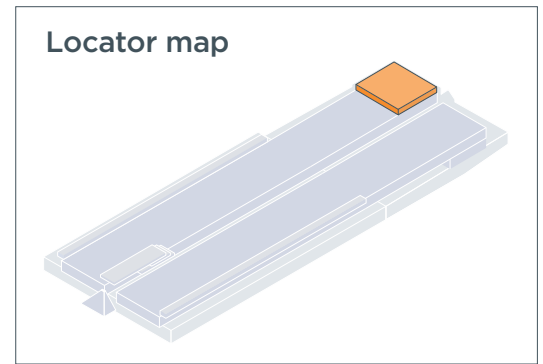

Key

- Individual fixing points to ceiling
50mm dia stainless steel CHS rated at 55 lbs with adjacent grommet connection panel.
- 32 AMP single phase supply
- 63 AMP single phase supply
- 63 AMP three phase supply
- Floor box location with power and data outlets
- Rigging frame
48.3mm dia stainless steel
275 lbs per bar, 110 lbs per metre with adjacent grommet connection panel
- Partition wall
- Organiser office
- Toilets**
- Male
- Female
- Accessible
- Public lifts
- Goods lifts

ICC Capital Suite - capacity chart

	Area	Dimensions	Height	Theatre	*Schoolroom	*Cabaret	*Banquet	Reception	Boardroom	U shape
Room 1	1,743 sq ft	42 ft x 42 ft	12 ft	150	75	80	100	150	30	36
Room 2	1,033 sq ft	25 ft x 42 ft	12 ft	88	44	48	60	88	20	22
Room 3	1,033 sq ft	25 ft x 42 ft	12 ft	88	44	48	60	88	20	22
Room 4	2,109 sq ft	51 ft x 42 ft	12 ft	180	90	96	120	180	30	42
Room 5	581 sq ft	29 ft x 20 ft	12 ft	50	24	n/a	n/a	50	18	n/a
Room 6	1,453 sq ft	29 ft x 50 ft	12 ft	124	62	72	80	124	30	30
Room 7	2,453 sq ft	51 ft x 49 ft	14.4 ft	220	105	112	140	210	50	45
Room 8	2,464 sq ft	51 ft x 49 ft	14.4 ft	220	105	112	140	210	50	45
Room 9	2,044 sq ft	42 ft x 49 ft	14.4 ft	180	87	88	110	175	50	39
Room 10	2,044 sq ft	42 ft x 49 ft	14.4 ft	180	87	88	110	175	50	39
Room 11	2,464 sq ft	51 ft x 49 ft	14.4 ft	220	105	112	140	210	50	45
Room 12	2,453 sq ft	51 ft x 49 ft	14.4 ft	220	105	112	140	210	50	45
Room 13	1,453 sq ft	29 ft x 50 ft	12 ft	124	62	72	80	124	30	30
Room 14	2,475 sq ft	51 ft x 49 ft	12 ft	220	105	112	140	210	30	45
Room 15	1,216 sq ft	25 ft x 49 ft	12 ft	60	52	56	60	60	20	36
Room 16	1,216 sq ft	25 ft x 49 ft	12 ft	60	52	56	60	60	20	36
Room 17	2,044 sq ft	42 ft x 49 ft	12 ft	180	87	88	110	175	30	39
Rooms 2-4	4,175 sq ft	100 ft x 42 ft	12 ft	356	178	192	240	356	50	n/a
Rooms 6+13	2,905 sq ft	100 ft x 29 ft	12 ft	248	124	144	170	248	60	n/a
Rooms 7-12	13,923 sq ft	143 ft x 97 ft	14.4 ft	1,394	594	640	800	1,394	n/a	n/a
Rooms 14-16	4,907 sq ft	101 ft x 49 ft	12 ft	418	209	224	280	418	50	n/a

All capacities subject to floorplan approval.

*Schoolroom numbers are based on three per table (using 6 ft trestle tables); *Cabaret numbers based on a max of eight per table (using 5 ft round tables); *Banquet numbers based on a max of ten per table (using 5 ft round tables).

Facilities

- Meeting space for up to 2,500 delegates
- 17 individual meeting rooms for up to 1,394 delegates
- Cloakroom
- Outside balconies: 6,099 sq ft total (3,049 sq ft each)
- Organisers office: 484 sq ft
- Registration area: 166 ft (l) x 26 ft (w), 1,378 sq ft total
- Two Reception areas: 153 ft (l) x 38.7 ft (w), 11,793 sq ft total (5,896 sq ft each)
- Maximum floor loading: 5.0 kN/10 sq ft
- 45Db noise resistant partition walls
- Heating and cooling
- Natural daylight in rooms 1, 2, 3, 4, 5, 6 and 13

Door dimensions

- 5.24 ft (w) x 7.54 ft (h)
- Distance between meeting room doors: 19.6 ft

Lift dimensions & weight loading

- Lift G5 size: 5.9 ft (w) x 8.9 ft (d) x 8.2 ft (h)
- Lift G6 size: 5.9 ft (w) x 8.9 ft (d) x 8.2 ft (h)
- Weight loading: 5,511 lbs

AV facilities

- Ability to relay video and sound feeds from one room to up to 15 other rooms at once
- Dimmable and programmable house light system
- Ability to deliver 'cable free' AV setups
- 63AMP or 32AMP power supplies available in each room

ICC Capital Lounge meeting rooms

Level 2

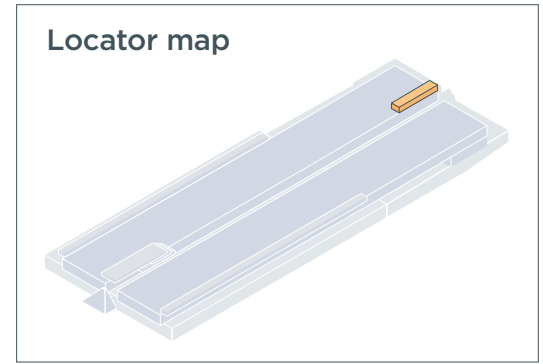

ICC Capital Lounge rooms - Boardroom style

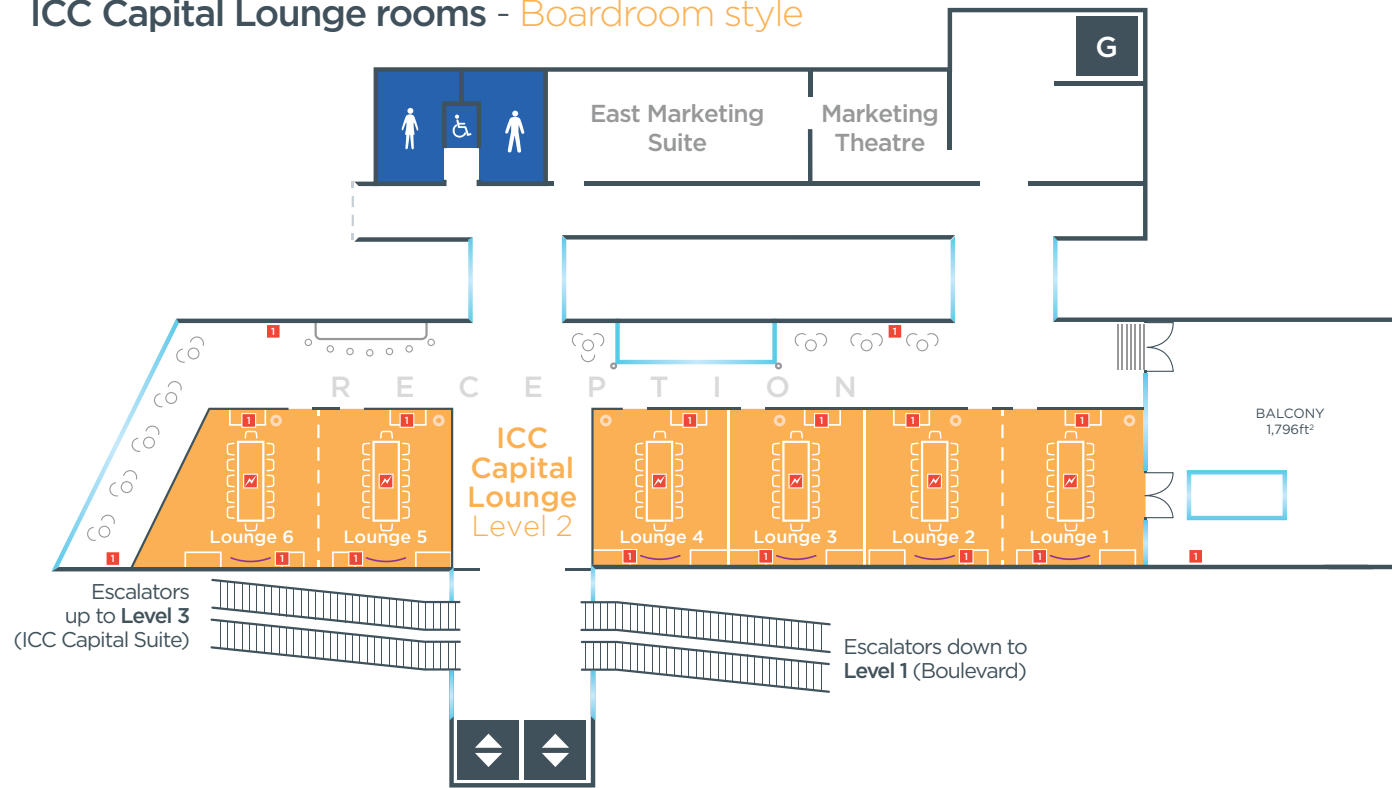

ICC Capital Lounge rooms - capacity chart

	Area	Dimensions	Height	Boardroom	Theatre
Room 1	398 sq ft	19 ft x 21 ft	8.9 ft	12	25
Room 2	441 sq ft	21 ft x 21 ft	8.9 ft	12	25
Room 3	420 sq ft	20 ft x 21 ft	8.9 ft	12	n/a
Room 4	420 sq ft	20 ft x 21 ft	8.9 ft	12	n/a
Room 5	387 sq ft	18 ft x 21 ft	8.9 ft	12	25
Room 6	366 sq ft	17 ft x 21 ft	8.9 ft	12	25
Rooms 1+2	839 sq ft	39 ft x 21 ft	8.9 ft	24	50
Rooms 5+6	753 sq ft	35 ft x 21 ft	8.9 ft	24	50

All capacities subject to floorplan approval.

Facilities

- Executive style boardroom and chairs
- Intelligent glass providing privacy solutions
- Partition walls (rooms 1 & 2 and 5 & 6)
- Wardrobe in each room
- 45Db noise partition wall (rooms 1 & 2 and 5 & 6)
- Digital signage outside each room
- Digital screen at main entrance doors
- Natural daylight (room 1 or rooms 1 & 2 combined)
- Heating and cooling

Reception

- Capacity of 300 including reception area
- Breakout area with a hospitality unit
- 13AMP power points

AV Inclusions

- 65" LED curved screens
- Built-in sound system
- Ability to stream content to two screens simultaneously (rooms 1 & 2 or 5 & 6 combined)

Key

- 1 13 AMP power points
- ⚡ 13 AMP supply floor boxes
- | Partition wall
- 65" LED curved screen
- ⊙ Reception area seating
- Column
- Toilets**
- ♂ Male
- ♀ Female
- ♿ Accessible
- ↕ Public lifts
- G6 Goods lifts

ICC Capital Lounge rooms - Theatre style

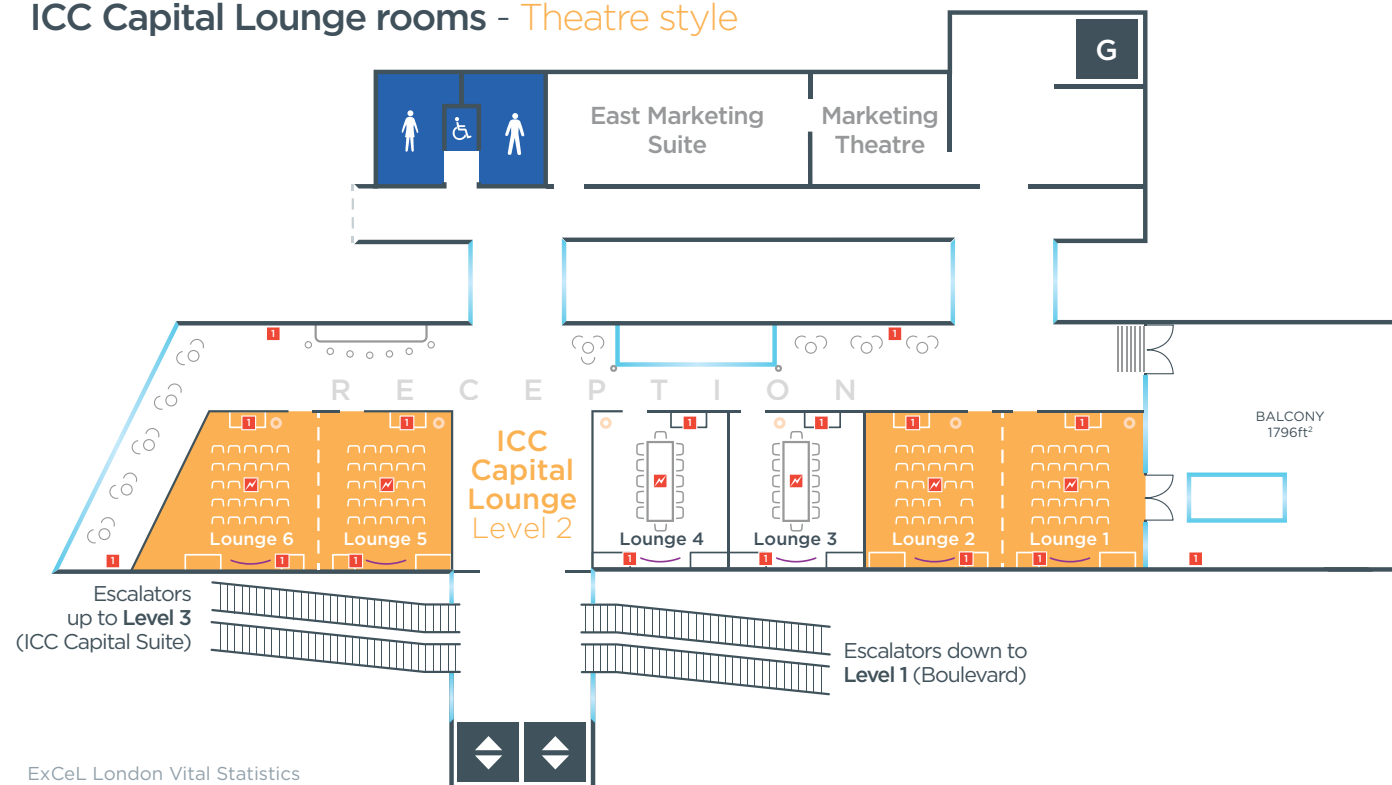

ICC London Suite

Level 0

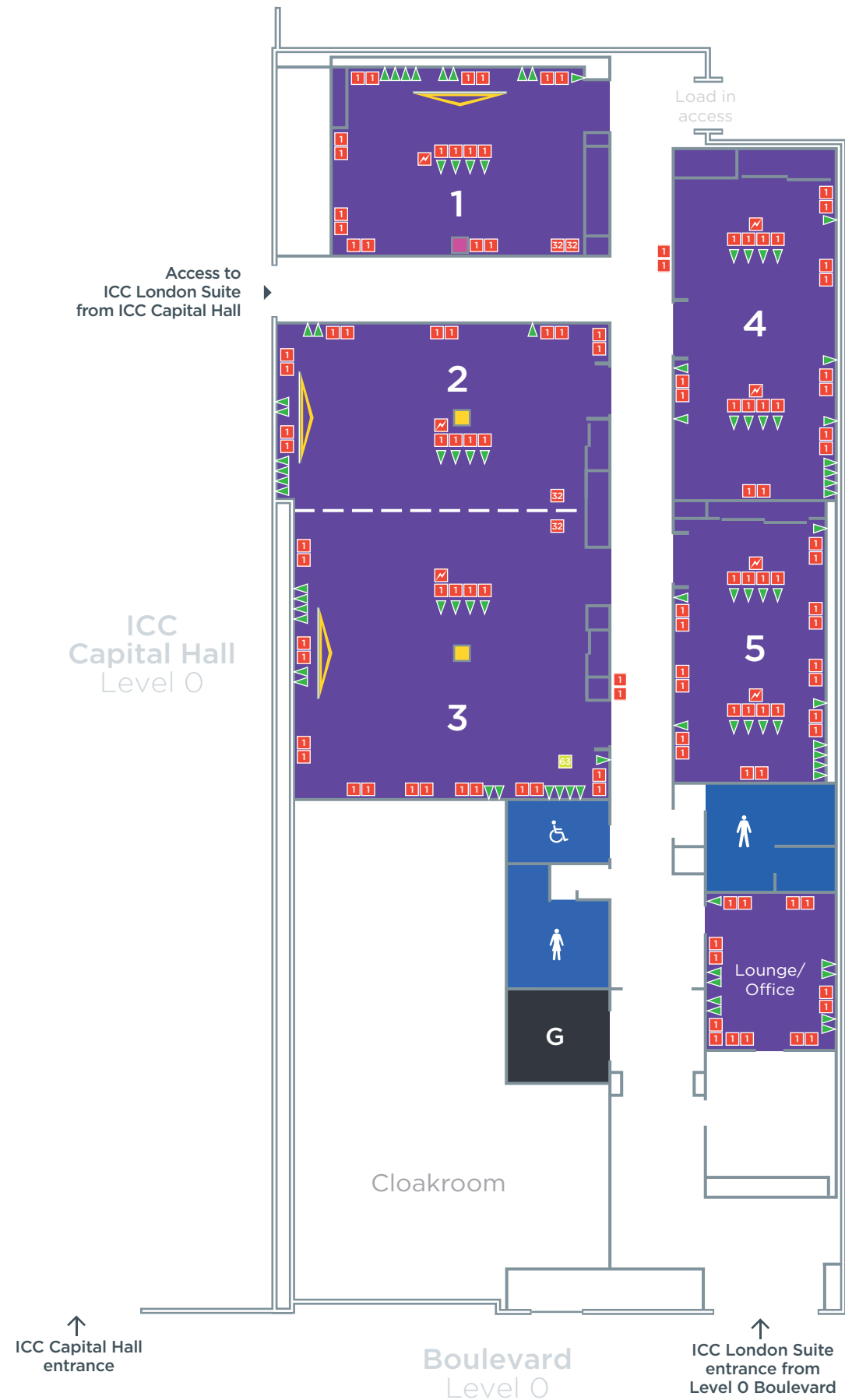
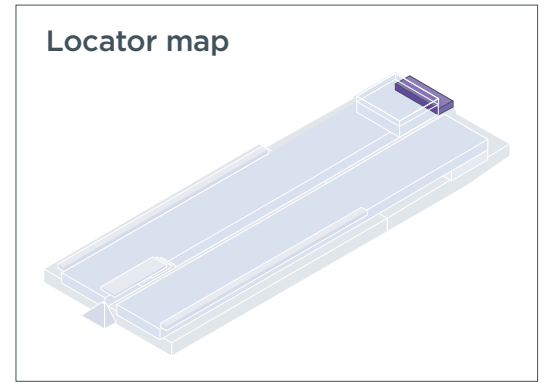

ICC London Suite - capacity chart

	Area	Dimensions	Height	Theatre	*Schoolroom	*Cabaret	*Banquet	Reception	Boardroom	U shape
Room 1	592 sq ft	28 ft x 21 ft	10.9 ft	56	18	32	40	56	20	16
Room 2	764 sq ft	34 ft x 21 ft	10.9 ft	60	24	32	40	60	24	20
Room 3	1,098 sq ft	32 ft x 32 ft	10.9 ft	112	40	48	60	112	32	24
Room 4	646 sq ft	36 ft x 17 ft	9.2 ft	60	24	24	30	60	22	n/a
Room 5	538 sq ft	30 ft x 17 ft	9.2 ft	50	16	16	20	50	20	n/a
Lounge/Office	215 sq ft	13 ft x 16 ft	9.2 ft	n/a	n/a	n/a	n/a	n/a	n/a	n/a
Rooms 2+3	1,861 sq ft	54 ft x 32 ft	10.9 ft	200	72	80	100	200	n/a	38

All capacities subject to floorplan approval.

*Schoolroom numbers are based on three per table (using 6 ft trestle tables); *Cabaret numbers based on a max of eight per table (using 5 ft round tables);

*Banquet numbers based on a max of ten per table (using 5 ft round tables).

Facilities

- 5 individual meeting rooms for up to 200 delegates
- Wardrobe available in each room
- Heating and cooling
- 45Db noise resistant partition wall (rooms 2 and 3)

Door dimensions

- 5.41 ft (w) x 6.69 ft (h)

Goods lift dimensions & weight loading

- Lift size: 5.9 ft (w) x 8.9 ft (d) x 8.2 ft (h)
- Door size: 4.6 ft (w) x 7.9 ft (h)
- Weight loading: 5,512 lbs

AV inclusions

- Rooms 4 to 5 and lounge:
 - 47" LED screen

Key

- 13 AMP supply
- 32 AMP single phase supply
- 63 AMP single phase supply
- Floor box location with power and data outlets
- Partition wall
- Projection screens
- Ceiling mounted data projection
- Wall mounted data projection
- Data point
- Toilets**
 - Male
 - Female
 - Accessible
- Goods lift

Prince Regent Rooms

Level 1

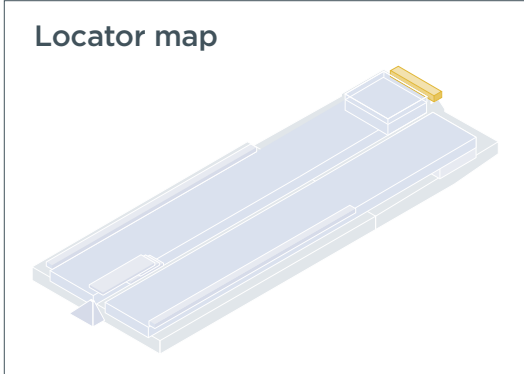
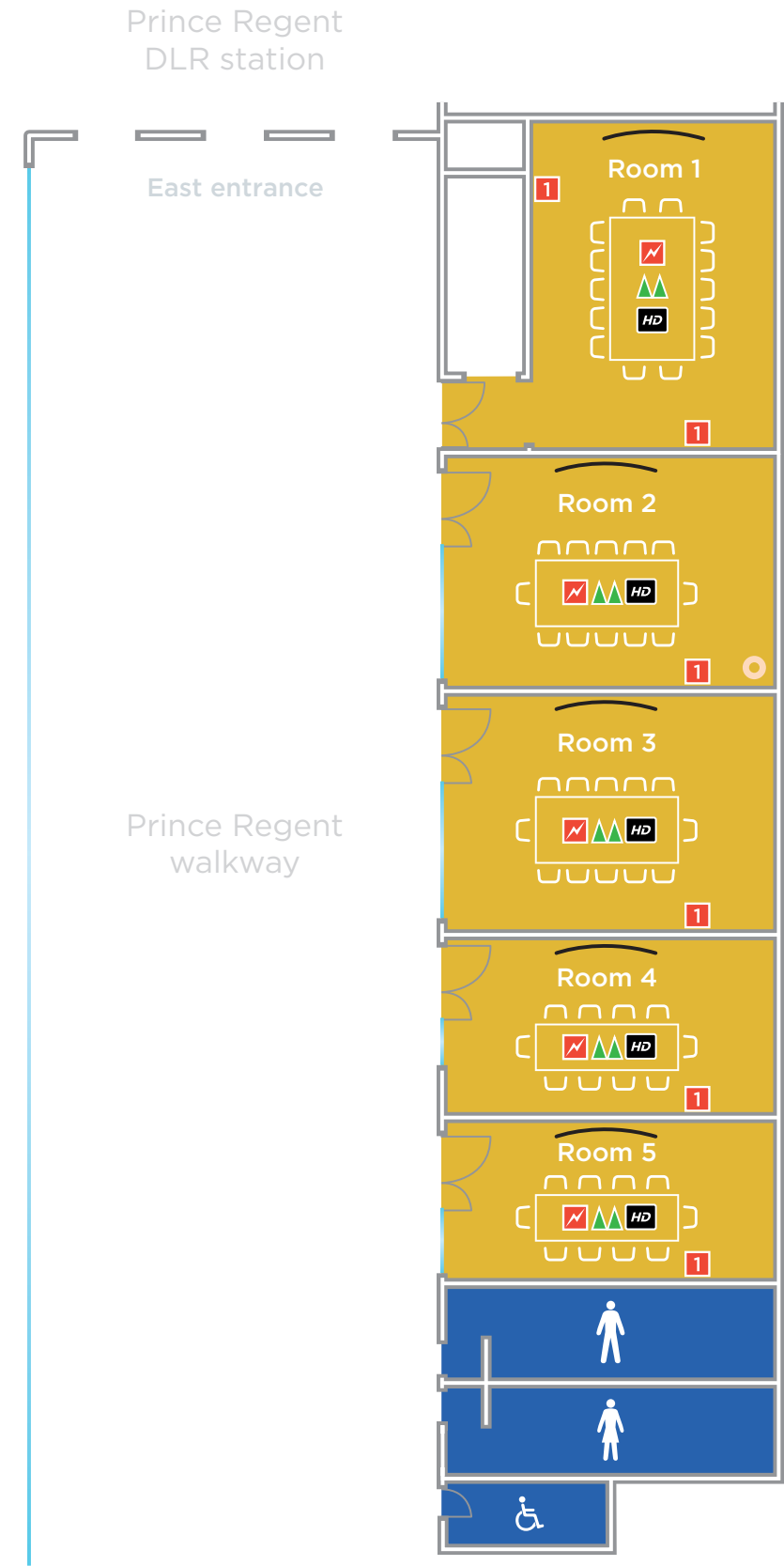

Prince Regent Rooms - capacity chart

	Area	Dimensions	Height	*Boardroom
Room 1	344 sq ft	16 ft x 21 ft	9.18 ft	14
Room 2	334 sq ft	22 ft x 16 ft	9.18 ft	12
Room 3	334 sq ft	22 ft x 15 ft	9.18 ft	12
Room 4	237 sq ft	22 ft x 11 ft	9.18 ft	10
Room 5	237 sq ft	22 ft x 11 ft	9.18 ft	10

*Boardrooms cannot be removed.

- Facilities**
- Executive style boardroom set up
 - AV facilities
 - Natural daylight (rooms 1 to 4)
 - Heating and cooling
 - Temperature control
- AV inclusions**
- Room 1: 75" LED screen
 - Rooms 2 to 5: 55" LED screen
 - IT connections to link laptop to screen
 - Conference phone

- Key**
- 1 13 AMP power points
 - M 13 AMP supply floor boxes
 - Column
 - HD HDMI outlet
 - ▶ Data point
 - Digital screen
- Toilets**
- ♂ Male
 - ♀ Female
 - ♿ Accessible

ICC Expansion

Event spaces

Key

- 1 ICC Maritime Halls 1-6 (Level 0)
- 2 Lower Boulevard (Level 0)
- 3 ICC Maritime Lounge (Level 2)
- 4 ICC Maritime Suite (Level 3)
- 5 Upper Boulevard (Level 3)
- 6 Prince Regent DLR (Level 1)

Level 3

Level 0

Level 2

R O Y A L
V I C T O R I A
D O C K

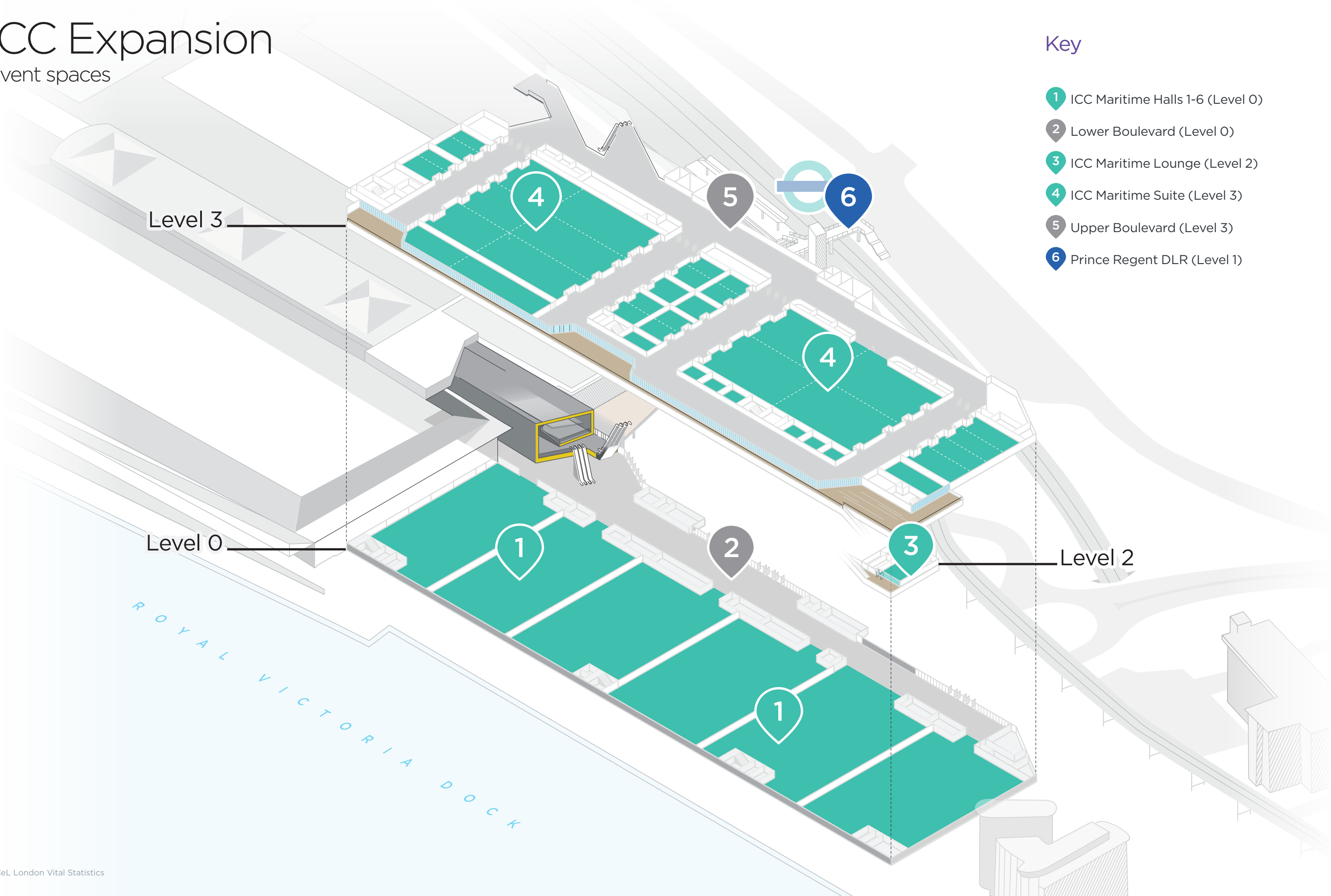

ICC Maritime Suite

Meeting spaces



Prince Regent DLR
for ExCeL ICC

Facilities

- Meeting space for up to 7,000 delegates
- 37 individual meeting rooms
- Cloakroom
- Maritime Lounge (Level 2): 964 sq ft
- Three external south-facing terraces
- Five organiser offices (215 sq ft each)
- Three large reception areas
- Boulevard: 24,434 sq ft (590 ft long)
- Natural daylight in Thames Rooms and Connaught Rooms
- Easy access to and from ICC Capital Suite
- Heating and cooling
- Maximum floor loading = 5.0 kN/10 sq ft
- 52-62Db noise resistant partition walls
- Dimmable and programmable house light system
- 63AMP, 32AMP or 16AMP power supplies available in each room

Door dimensions

- 6.8 ft (w) x 6.8 ft / 9.8 ft (h)
- Distance between meeting room doors: 26 ft-49 ft

Goods lift dimensions & weight loading

- Lifts G1 size: 11.5 ft (w) x 16.4 ft (d) x 8.2 ft (h)
- Lifts G2 size: 6.6 ft (w) x 16.4 ft (d) x 6.6 ft (h)
- Weight loading: 5,511 lbs

Key

- Event Rooms
- Upper Boulevard
- Organiser offices
- Toilets
 - Male
 - Female
 - Accessible
- Stairs
- Public lifts
- Goods lifts G1 G2



ICC Maritime Suite meetings rooms - capacity chart

	Area	Dimensions	Height	Reception	Theatre	Schoolroom*	Cabaret*	Banquet	Boardroom	U-shape
Greenwich Room 1	939 sq ft	32.2 ft x 28.9 ft	13.5 ft	105	90	45	55	50	25	17
Greenwich Room 2	989 sq ft	34.1 ft x 28.9 ft	13.5 ft	105	90	45	55	50	25	17
Greenwich Room 3	996 sq ft	34.1 ft x 28.9 ft	13.5 ft	105	90	45	55	50	25	17
Greenwich Room 4	939 sq ft	34.1 ft x 27.2 ft	13.5 ft	105	90	45	55	50	25	17
Victoria Room 1	5,202 sq ft	73.8 ft x 70.5 ft	18 ft	455	410	200	240	300	n/a	n/a
Victoria Room 2	4,362 sq ft	73.8 ft x 59.1 ft	18 ft	370	335	165	195	245	n/a	n/a
Victoria Room 3	3,395 sq ft	73.8 ft x 45.9 ft	18 ft	275	275	135	160	200	n/a	n/a
Victoria Room 4	6,956 sq ft	98.8 ft x 70.5 ft	18 ft	600	540	270	320	400	n/a	n/a
Victoria Room 5	5,833 sq ft	98.8 ft x 59.1 ft	18 ft	495	450	225	260	330	n/a	n/a
Victoria Room 6	4,540 sq ft	98.8 ft x 45.9 ft	18 ft	410	370	185	215	270	n/a	n/a
Victoria Room 7	2,557 sq ft	77.4 ft x 34.8 ft	13.5 ft	210	190	95	110	140	48	35
Victoria Room 8	3,389 sq ft	103 ft x 34.8 ft	13.5 ft	300	265	130	155	195	66	50
Victoria Rooms 1-6	30,288 sq ft	172.6 ft x 175.2 ft	18 ft	2,605	2,380	1,180	1,390	1,745	n/a	n/a
Victoria Rooms 7-8	5,946 sq ft	180.4 ft x 33.5 ft	13.5 ft	510	455	225	265	335	n/a	n/a
Albert Room 1	933 sq ft	33.8 ft x 27.6 ft	13.5 ft	85	78	39	46	58	20	15
Albert Room 2	964 sq ft	33.8 ft x 28.5 ft	13.5 ft	85	78	39	46	58	20	15
Albert Room 3	1,330 sq ft	33.8 ft x 39.4 ft	13.5 ft	120	110	55	64	80	27	20
Albert Room 4	1,086 sq ft	33.8 ft x 31.8 ft	13.5 ft	100	88	44	50	65	22	16
Albert Room 5	886 sq ft	33.8 ft x 25.9 ft	13.5 ft	80	75	37	44	55	18	14
Trinity Room 1	928 sq ft	33.5 ft x 27.6 ft	13.5 ft	85	78	39	46	58	20	15
Trinity Room 2	959 sq ft	33.5 ft x 28.5 ft	13.5 ft	85	78	39	46	58	20	15
Trinity Room 3	1,323 sq ft	33.5 ft x 39.4 ft	13.5 ft	120	110	55	64	80	27	20
Trinity Room 4	1,080 sq ft	33.5 ft x 31.8 ft	13.5 ft	100	88	44	50	65	22	16
Trinity Room 5	880 sq ft	33.5 ft x 25.9 ft	13.5 ft	80	75	37	44	55	18	14
Trinity Room 6	697 sq ft	32.8 ft x 21 ft	13.5 ft	59	54	26	24	30	15	10
George V Room 1	7,162 sq ft	99.4 ft x 70.5 ft	18 ft	610	550	275	322	407	n/a	n/a
George V Room 2	8,489 sq ft	99.4 ft x 85.3 ft	18 ft	735	665	330	390	490	n/a	n/a
George V Room 3	7,162 sq ft	99.4 ft x 70.5 ft	18 ft	615	555	280	325	410	n/a	n/a
George V Room 4	8,489 sq ft	99.4 ft x 85.3 ft	18 ft	735	665	330	390	490	n/a	n/a
George V Rooms 1-4	31,301 sq ft	198.8 ft x 155.8 ft	18 ft	2,695	2,435	1,215	1,427	1,797	n/a	n/a
Thames Room 1	515 sq ft	23.6 ft x 21.7 ft	9 ft	42	38	18	16	20	12	9
Thames Room 2	541 sq ft	24.9 ft x 21.7 ft	9 ft	30	28	14	16	20	10	8
Thames Room 3	480 sq ft	24 ft x 19 ft	9 ft	30	28	14	16	20	10	8
Thames Room 4	522 sq ft	24 ft x 21.7 ft	9 ft	42	38	18	16	20	12	9
Thames Room 5	539 sq ft	24.9 ft x 21.7 ft	9 ft	42	38	18	16	20	12	9
Thames Room 6	556 sq ft	25.6 ft x 21.7 ft	9 ft	42	38	18	16	20	12	9
Connaught Room 1	2,404 sq ft	58.7 ft x 40.7 ft	13.5 ft	210	210	103	121	154	50	40
Connaught Room 2	1,768 sq ft	58.7 ft x 29.9 ft	13.5 ft	160	145	72	85	107	36	26
Connaught Room 3	1,768 sq ft	58.7 ft x 29.9 ft	13.5 ft	160	145	72	85	107	36	26
Connaught Room 4	1,814 sq ft	58.7 ft x 30.8 ft	13.5 ft	160	145	72	85	107	36	26
Connaught Rooms 1-3	7,754 sq ft	58.7 ft x 131.2 ft	13.5 ft	530	500	247	291	368	n/a	n/a

All dimensions and capacities may be subject to final fire strategy modelling.

*Schoolroom density based on three people per table; *Cabaret numbers based on a max of eight people per table (using 5 ft round tables).

ICC Maritime Halls

Halls 1-6

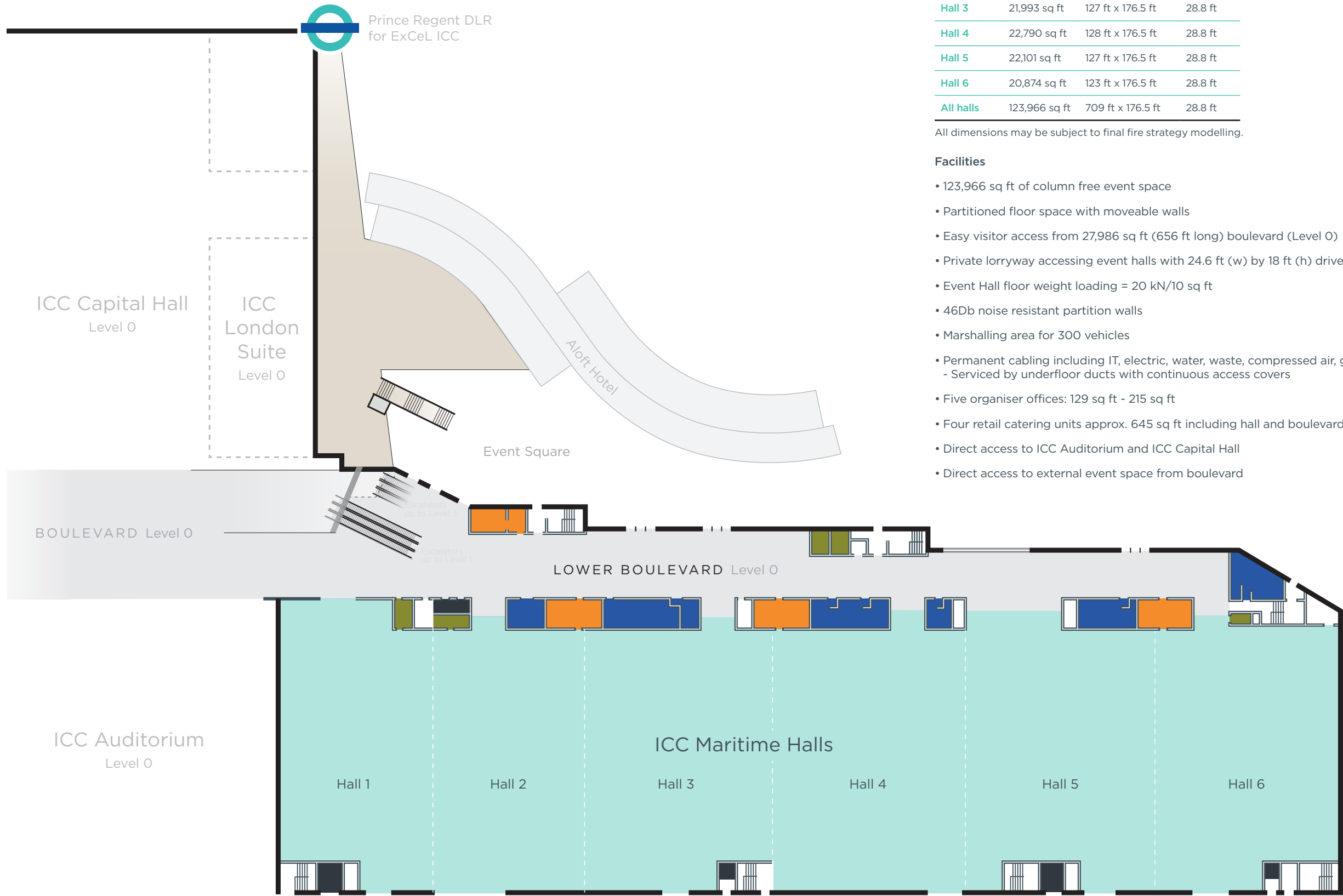

ICC Maritime Halls

	Area	Dimensions	Height
Hall 1	17,991 sq ft	102 ft x 176.5 ft	28.8 ft
Hall 2	18,217 sq ft	102 ft x 176.5 ft	28.8 ft
Hall 3	21,993 sq ft	127 ft x 176.5 ft	28.8 ft
Hall 4	22,790 sq ft	128 ft x 176.5 ft	28.8 ft
Hall 5	22,101 sq ft	127 ft x 176.5 ft	28.8 ft
Hall 6	20,874 sq ft	123 ft x 176.5 ft	28.8 ft
All halls	123,966 sq ft	709 ft x 176.5 ft	28.8 ft

All dimensions may be subject to final fire strategy modelling.

Facilities

- 123,966 sq ft of column free event space
- Partitioned floor space with moveable walls
- Easy visitor access from 27,986 sq ft (656 ft long) boulevard (Level 0)
- Private lorryway accessing event halls with 24.6 ft (w) by 18 ft (h) drive-in doorways
- Event Hall floor weight loading = 20 kN/10 sq ft
- 46Db noise resistant partition walls
- Marshalling area for 300 vehicles
- Permanent cabling including IT, electric, water, waste, compressed air, gas - Serviced by underfloor ducts with continuous access covers
- Five organiser offices: 129 sq ft - 215 sq ft
- Four retail catering units approx. 645 sq ft including hall and boulevard facing units
- Direct access to ICC Auditorium and ICC Capital Hall
- Direct access to external event space from boulevard

Key

- ICC Maritime Halls
- Lower Boulevard
- Organiser offices
- Toilets
- Retail catering (Boulevard)
- Stairs
- Lifts

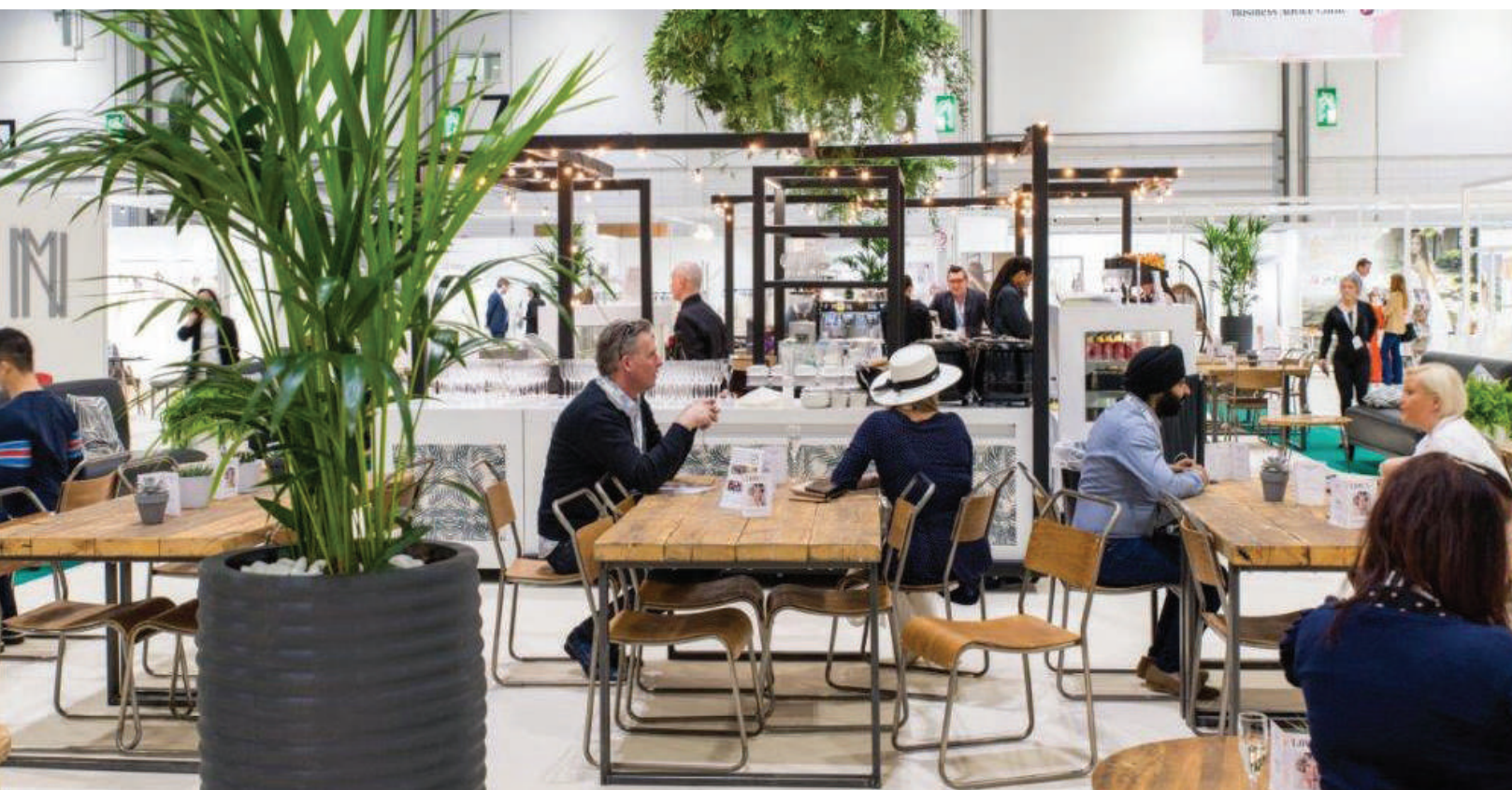

EXCeL
LONDON

ExCeL London

One Western Gateway
Royal Victoria Dock
London E16 1XL

Telephone +44 (0)20 7069 4602

Sales Enquiries – Conferences & Events and Exhibitions

SalesEnquiries@excel.london

www.excel.london

ADNEC
مجموعة أدنيك GROUP

About ADNEC Group

ADNEC Group is an international venue development and business management company. ADNEC Group's portfolio currently includes the Abu Dhabi National Exhibition Centre, the Gulf's largest exhibition centre; ExCeL London, the UK capital's largest conference and exhibition centre; the Al Ain Convention Centre, a brand new development in the historic city of Al Ain, Capital Gate, the UAE capital's iconic, gravity defying tower and a number of hotel projects. In addition ADNEC is master developer of the Capital Centre project, the world's first fully interconnected exhibition lifestyle destination.

ADNEC Group is developing its network both through acquisition and construction. The company's objective is to become the world's leading venue provider to the international exhibitions, conferences and live events industries by providing consistently high standards of venue facilities, management and client relationships, whilst capitalising on the synergies which exist within a global venue network.

ADNEC Group's Executive Office is located in Abu Dhabi, the capital city of the United Arab Emirates.

www.adnec.ae

